

Direct-acting 2 way standard solenoid control valve



Type 2871 can be combined with...



Type 8605
Digital control electronics DIN-rail version



Type 2507
Cable plug



Type 8611
Universal controller



The direct-acting solenoid control valve Type 2871 is used as the regulating unit in control loops. Due to an elastomeric seat seal the valve closes tight (integrated shut-off function), up to the DN specific nominal pressure. The plunger of the valve is assembled frictionless, which leads to an extraordinary adjustment characteristic. This valve is particularly suitable for demanding control tasks (high control range, dry gases, etc.).

Circuit function A

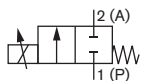

2/2 way direct-acting, solenoid proportional control valve

Valve control takes place through a PWM signal¹⁾. The duty cycle of the PWM signal determines the coil current and hence the position of the plunger. Optionally the valve can also be driven with DC voltage.

Please note the sizing comments for such a control valve on page 2.

¹⁾ PWM pulse width modulation

²⁾ Pressure data [bar]: Measured as overpressure to the atmospheric pressure, nominal pressure further depends on orifice size

³⁾ Maximum value, value depends on operating pressure

⁴⁾ Characteristic data of control behaviour depends on process conditions

⁵⁾ By flow measurement

- Excellent range
- Very good response
- Compact valve design
- Orifice sizes 0.05 ... 2.0 mm
- Port connection 1/8" or sub-base

Technical Data - Valve

Body material	Brass, stainless steel
Seal material	FKM, EPDM on request
Medium	Neutral gases, liquids on request
Pressure range	0 ... 12 bar ²⁾ – also applicable for technical vacuum
Medium temperature	-10 ... +90 °C
Ambient temperature	max. +55 °C
Power supply	24 V DC
PWM frequency	1500 Hz
Max. coil current	220 mA ³⁾
Power consumption	2 W (up to DN0.6), 5 W (from DN0.8)
Duty cycle	100 % continuously rated
Port connection	Sub-base, G 1/8, NPT 1/8, others on request
Electrical connection	Cable plug Type 2507, Form B industrial standard
Installation	As required, preferably with actuator in upright position
Typical control data⁴⁾ at PWM control	
Hysteresis	< 5 %
Repeatability	< 0.25 % FS ⁵⁾
Sensitivity	< 0.25 % FS – < 0.1 % FS with DN < 0.8 mm ⁵⁾
Span	1:200 (DN0.8-2), 1:500 (DN0.05-0.6)
Response time (10-90 %)	< 15 ms
Protection class valve	IP65

Technical data - Control electronics Type 8605 (see separate data sheet)

The valve control can take place through the control electronics of Type 8605, which converts an analogue input signal into a PWM signal.

Further functional features of the Type 8605 electronic control unit:

- Temperature compensation for coil heating by internal current regulation
- Simple adaptation of zero and span settings
- Ramp function to dampen fast set point changes

Characteristics of a solenoid control valve

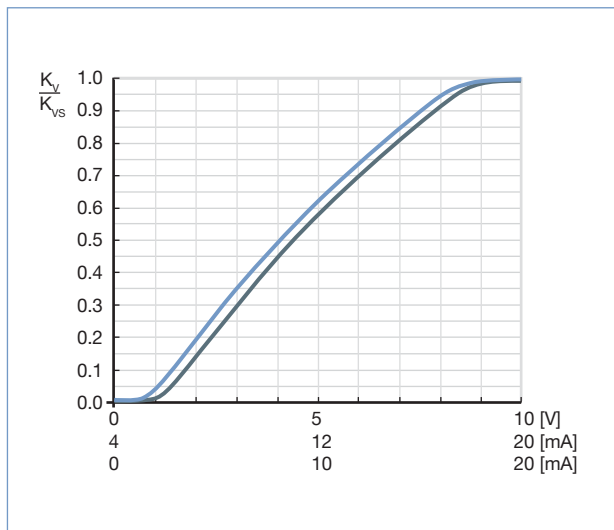

Advice for valve sizing

In continuous flow applications, the choice of an appropriate valve size is much more important than with on/off valves. The optimum size should be selected such that the resulting flow in the system is not unnecessarily reduced by the valve. However, a sufficient part of the pressure drop should be taken across the valve even when it is fully opened.

Recommended value: $\Delta p_{\text{valve}} > 25\%$ of total pressure drop within the system

Otherwise, the ideal, linear valve curve characteristic is changed.

If the differential pressure (difference between inlet and outlet pressure) exceeds half the value of the nominal pressure, the characteristics may change.

For that reason take advantage of Bürkert competent engineering services during the planning phase!

Determination of the k_v value

Pressure drop	k_v value for liquids [m ³ /h]	k_v value for gases [m ³ /h]
Subcritical $p_2 > \frac{p_1}{2}$	$= Q \sqrt{\frac{\rho}{1000 \Delta p}}$	$= \frac{Q_N}{514} \sqrt{\frac{T_1 \rho_N}{p_2 \Delta p}}$
Supercritical $p_2 < \frac{p_1}{2}$	$= Q \sqrt{\frac{\rho}{1000 \Delta p}}$	$= \frac{Q_N}{257 p_1} \sqrt{T_1 \rho_N}$

k_v	Flow coefficient	[m ³ /h] ⁶⁾
Q_N	Standard flow rate	[m ³ /h] ⁷⁾
p_1	Inlet pressure	[bar] ⁸⁾
p_2	Outlet pressure	[bar] ⁸⁾
Δp	Differential pressure $p_1 - p_2$	[bar]
ρ	Density	[kg/m ³]
ρ_N	Standard density	[kg/m ³]
T_1	Medium temperature	[(273+t)K]

⁶⁾ measured for water 20 °C, Δp 1 bar over the value

⁷⁾ At reference conditions 1.013 bar and 0 °C (273K)

⁸⁾ Absolute pressure

Dimensions for threaded body version [mm]

Threaded body

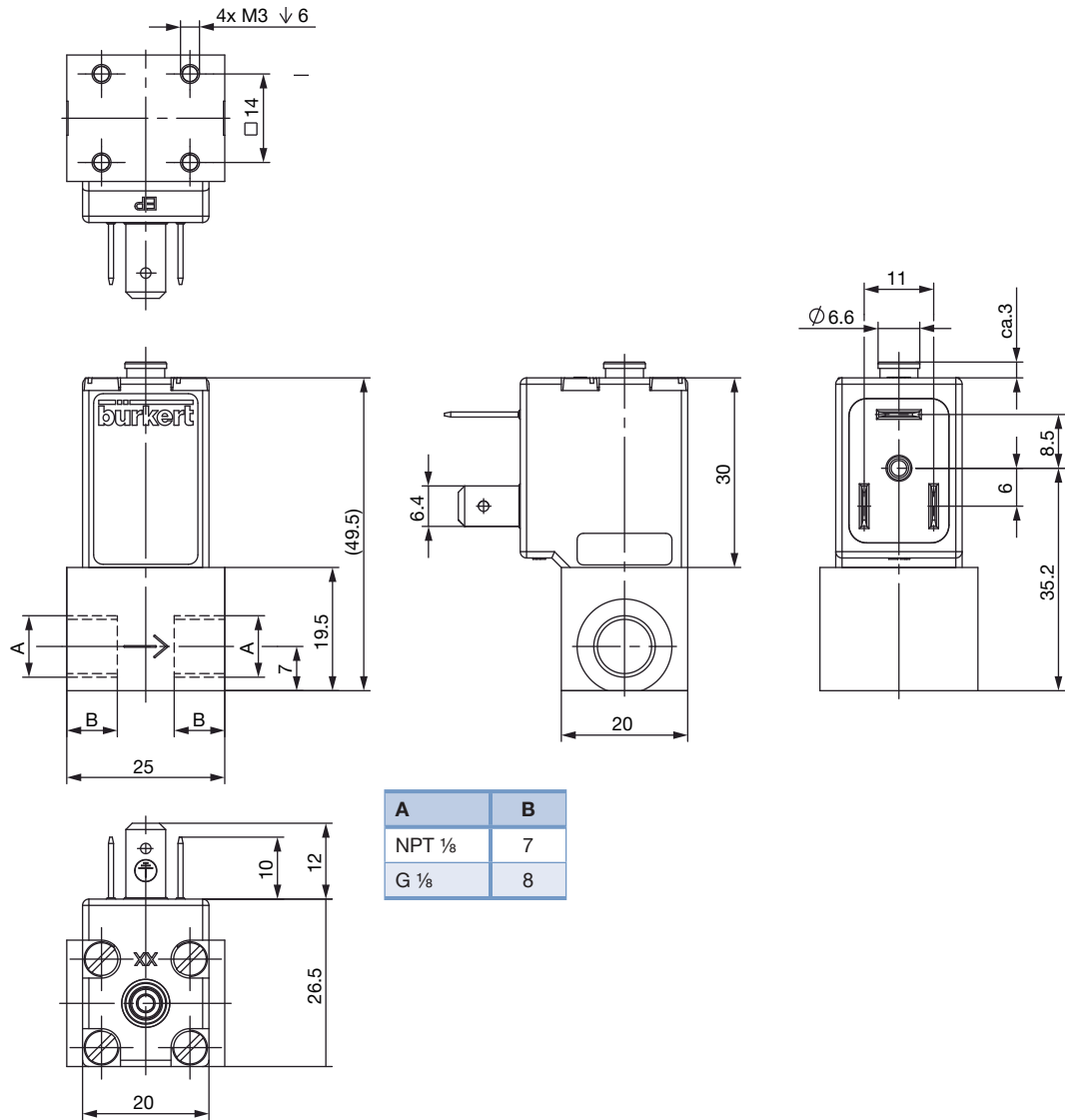

Flying leads version

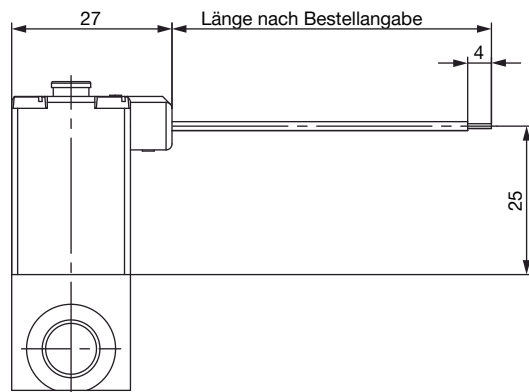

Dimensions for sub-base body version [mm]

Sub-base body

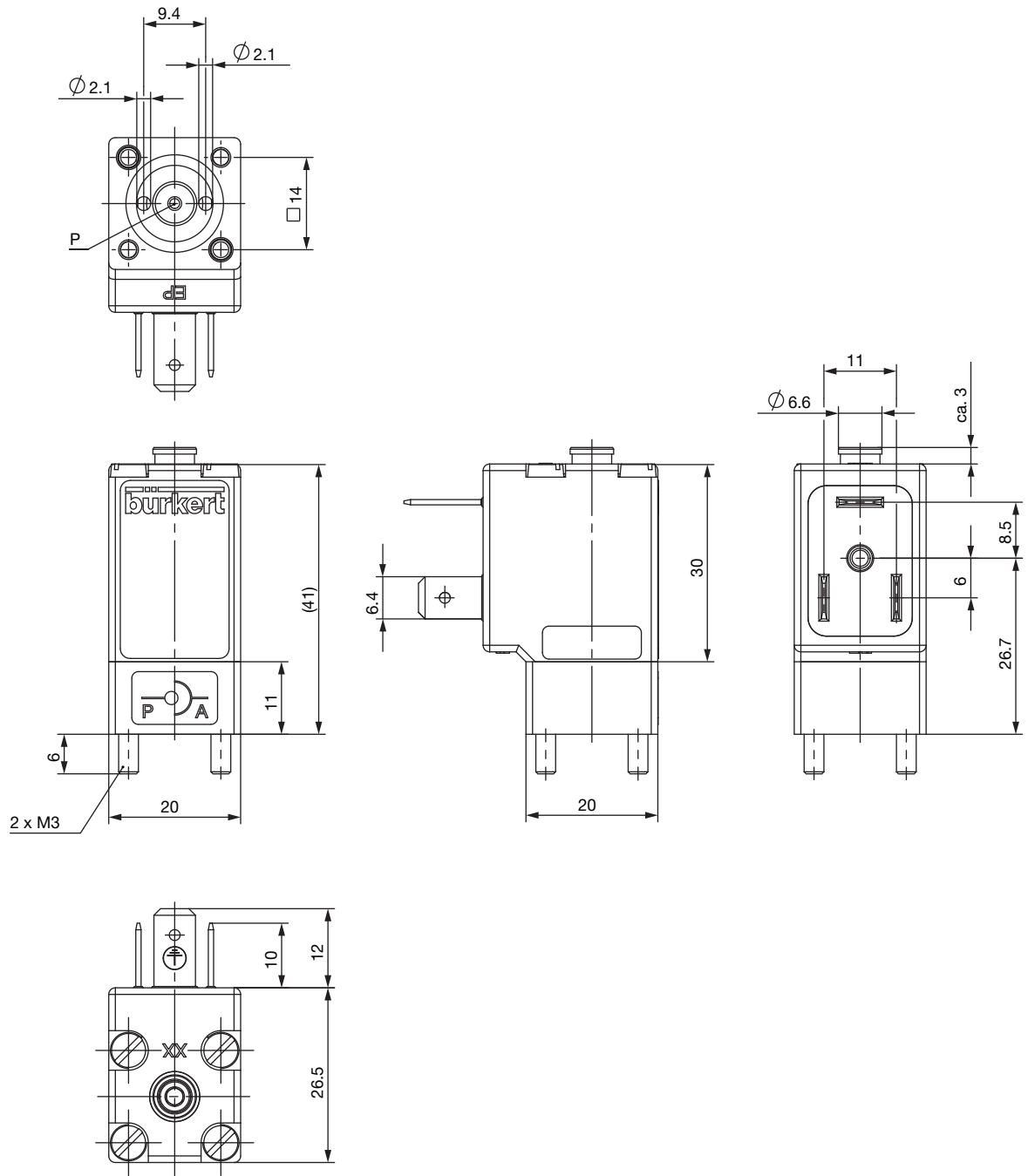

Ordering chart

All valves with FKM seals (DN0.05 and DN0.1 with PCTFE seat seal)

Circuit function	Orifice [mm]	Port connection	k_{vs} value water [m ³ /h] ⁹⁾	Nominal pressure [bar] ¹⁰⁾	Max. differential pressure [bar]	Article no. Brass	Article no. Stainless steel
	0.05	sub-base FK01	0.00006	10	10	254985	254986
		G 1/8	0.00006	10	10	254443	254444
		NPT 1/8	0.00006	10	10	254968	254971
	0.1	sub-base FK01	0.00025	10	10	254987	254988
		G 1/8	0.00025	10	10	254446	254447
		NPT 1/8	0.00025	10	10	254972	254973
	0.2	sub-base FK01	0.001	10	10	254989	254990
		G 1/8	0.001	10	10	254448	254450
		NPT 1/8	0.001	10	10	254974	254975
	0.3	sub-base FK01	0.002	10	10	254991	254992
		G 1/8	0.002	10	10	254451	254452
		NPT 1/8	0.002	10	10	254977	254978
	0.4	sub-base FK01	0.004	8	8	254993	254994
		G 1/8	0.004	8	8	254453	254454
		NPT 1/8	0.004	8	8	254979	254980
	0.6	sub-base FK01	0.01	6	6	254995	254996
		G 1/8	0.01	6	6	254455	254457
		NPT 1/8	0.01	6	6	254981	254982
	0.8	sub-base FK01	0.018	12	6	235992	235993
		G 1/8	0.018	12	6	235994	235995
		NPT 1/8	0.018	12	6	235996	235997
	1.0	sub-base FK01	0.027	10	5	235998	235999
		G 1/8	0.027	10	5	236000	236001
		NPT 1/8	0.027	10	5	236002	236003
	1.2	sub-base FK01	0.038	8	4	236004	236260
		G 1/8	0.038	8	4	236261	236262
		NPT 1/8	0.038	8	4	236263	236264
1.6	sub-base FK01	0.055	6	3	236265	236266	
	G 1/8	0.055	6	3	236267	236268	
	NPT 1/8	0.055	6	3	236269	236270	
2.0	sub-base FK01	0.090	3	1.5	236271	236272	
	G 1/8	0.090	3	1.5	236273	236274	
	NPT 1/8	0.090	3	1.5	236275	236276	

⁹⁾ k_{vs} value: Flow rate value for water, measured at +20 °C and 1 bar pressure differential over a fully opened valve.

¹⁰⁾ Pressure data [bar]: Overpressure with respect to atmospheric pressure, with a differential pressure (difference between inlet and outlet pressure) above half of the nominal pressure there are discontinuities in the valve's characteristics possible."

Please note that the valves are delivered without control electronics and cable plug (see accessory ordering information).

Ordering chart - variants with approvals

All valves with FKM seals (DN0.05 and DN0.1 with PCTFE seat seal)

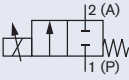
Circuit function	Orifice [mm]	Approvals ¹¹⁾	Port ¹²⁾ connection	k _{vs} value water [m ³ /h]	Nominal pressure [bar]	Max. differential pressure [bar]	Article no. Brass	Article no. Stainless steel
	0.05	UR	G 1/8	0.00006	10	10	274900	274904
			NPT 1/8	0.00006	10	10	274901	274905
	0.1	UR	G 1/8	0.00025	10	10	274902	274906
			NPT 1/8	0.00025	10	10	274903	274907
	0.2	UR	G 1/8	0.001	10	10	274908	274926
			NPT 1/8	0.001	10	10	274909	274927
	0.3	UR	G 1/8	0.002	10	10	274910	274928
			NPT 1/8	0.002	10	10	274911	274929
	0.4	UR	G 1/8	0.004	8	8	274912	274930
			NPT 1/8	0.004	8	8	274913	274931
	0.6	UR	G 1/8	0.01	6	6	274914	274932
			NPT 1/8	0.01	6	6	274915	274933
	0.8	UR	G 1/8	0.018	12	6	274916	274934
			NPT 1/8	0.018	12	6	274917	274935
	1.0	UR	G 1/8	0.027	10	5	274918	274936
			NPT 1/8	0.027	10	5	274919	274937
	1.2	UR	G 1/8	0.038	8	4	274920	274938
			NPT 1/8	0.038	8	4	274921	274939
1.6	UR	G 1/8	0.055	6	3	274922	274940	
		NPT 1/8	0.055	6	3	274923	274941	
2.0	UR	G 1/8	0.090	3	1.5	274924	274942	
		NPT 1/8	0.090	3	1.5	274925	274943	

¹¹⁾ Approvals: UR (UL recognized)¹²⁾ Port connection: others on request.**Note:** Delivered without electronic control, Type 8605 and cableplug (see ordering table for accessories).

Ordering chart - variants for higher differential pressures

All valves with FKM seal

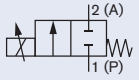
Circuit function	Orifice [mm]	Approvals	Port connection	k_{vs} value water [m ³ /h]	Nominal pressure [bar]	Article no. Brass	Article no. Stainless steel
 A	0.8		G 1/8	0.018	12	238928	238930
		UR	G 1/8	0.018	12	275025	275030
	1.0		G 1/8	0.027	10	238936	238931
		UR	G 1/8	0.027	10	275026	275031
	1.2		G 1/8	0.038	8	238937	238932
		UR	G 1/8	0.038	8	275027	275032
	1.6		G 1/8	0.055	6	238939	238933
		UR	G 1/8	0.055	6	275028	275033
	2.0		G 1/8	0.090	3	238940	238934
		UR	G 1/8	0.090	3	275029	275034

Note: The following technical data changes compared with the data on page 1
 PWM frequency 800 Hz, span 1:100.
 Other connection variations (sub-base, NPT) on request.

Ordering chart for accessories

Cable plug Type 2507, form B

The delivery of a cable plug includes the flat seal and fixing screw

Circuitry	Voltage / frequency	Article no.
Without circuitry	0 ... 250 V AC/DC	423845

Control electronics, Type 8605 – see separate datasheet

Further versions on request



Materials

Seal materials EPDM, FFKM



Analytical

Oxygen version
 Parts oil-, fat- and silicon free

Electrical connection



12 V Coil
 Wire leads 300 mm



Approvals

UR (UL recognized)

Note

You can fill out the fields directly in the PDF file before printing out the form.

Design data for solenoid control valves

▶ Please fill out this form and send to your local Bürkert Sales Centre* with your inquiry or order

Company	Contact person
Customer No	Department
Address	Tel./Fax
Postcode/Town	E-mail

= Mandatory fields Quantity Requested delivery date

Process data

Medium

State of medium liquid gaseous

Medium temperature °C

Maximum flow rate $Q_{nom} =$ Unit:

Minimum flow rate $Q_{min} =$ Unit:

Inlet pressure at nominal operation $p_1 =$ barg

Outlet pressure at nominal operation $p_2 =$ barg

Max. inlet pressure (nominal pressure) $p_{1max} =$ barg

Ambient temperature °C

Additional specifications

Body material Brass Stainless steel

Seal material FKM other

Note Please state all pressure values as overpressures with respect to atmospheric pressure [barg].

Standard series of solenoid control valves

 <p>Type 2871 Orifice 0.05 to 2 mm 20 mm coil width</p>	 <p>Type 2873 Orifice 0.8 to 6.0 mm 32 mm coil width</p>	 <p>Type 2875 Orifice 2.0 to 9.5 mm 49 mm coil width</p>
---	--	--

To find your nearest Bürkert facility, click on the orange →

www.burkert.com

In case of special application conditions, please consult for advice.

Subject to alteration.
© Christian Bürkert GmbH & Co. KG

1902/9_EU-en_00895220